

Table of Contents

| | |
|---|---|
| 1.0 General..... | 3 |
| 2.0 Introduction..... | 3 |
| 3.0 Precautions..... | 4 |
| 4.0 Pre-survey | 5 |
| 5.0 Materials and Equipment..... | 5 |
| 6.0 Placing Cable Using the Moving Reel Method..... | 6 |
| 7.0 Placing Cable Using the Stationary Reel Method..... | 8 |

List of Illustrations and Tables

| | |
|---|---|
| Figure 1 Moving Reel Method of Cable Placement | 3 |
| Figure 2 Stationary Reel Method of Cable Placement..... | 3 |
| Figure 3 Cable Block | 5 |
| Figure 4 Strand Storage | 6 |
| Figure 5 Splice Van Location..... | 6 |
| Figure 6 Lashing Wire Clamp | 7 |
| Figure 7 Setup for Moving Reel Method | 7 |
| Figure 8 Setup for Stationary Reel Method..... | 8 |
| Figure 9 Snatch Block | 9 |
| Figure 10 Pull-Back Lashing of Cable | 9 |

DISCLAIMER OF WARRANTIES AND LIMITATION OF LIABILITIES

The practices contained herein are designed as a guide for use by persons having technical skill at their own discretion and risk. The recommended practices are based on average conditions. Panduit does not guarantee any favorable results or assume any liability in connection with this document.

In addition, the materials and hardware referenced herein appear as examples, but in no way reflect the only tools and materials available to perform these installations.

Local, State, Federal and Industry Codes and Regulations, as well as manufacturers requirements, must be consulted before proceeding with any project. Panduit makes no representations of, nor assumes any responsibility for, the accuracy or completeness of this document. Panduit disclaims any liability arising from any information contained herein or for the absence of same.

1.0 GENERAL

- 1.01** This procedure provides general information for the installation of aerial fiber optic cables. The methods described are intended for guideline use only, as it is impossible to cover all the various conditions that may arise during an installation. Individual company practices for placing aerial fiber optic cable should supersede any conflicting instructions in this document when they do not exceed the cable's optical and mechanical performance specifications.
- 1.02** Placement methods for aerial fiber optic cable are very similar to those of strand-supported copper cable. However it must be kept in mind that fiber optic cable is a high capacity transmission medium which can have its transmission characteristics degraded when subjected to excessive pulling force, sharp bends, and crushing forces. These losses may not be revealed until long after installation is complete. For these reasons extra care must be taken during the entire installation procedure.
- 1.03** It is assumed that the personnel using the information presented in this document have prior experience in the planning, engineering or placement of aerial cable.

2.0 INTRODUCTION

- 2.01** Two basic methods of lashing fiber optic cable are presented in this document:

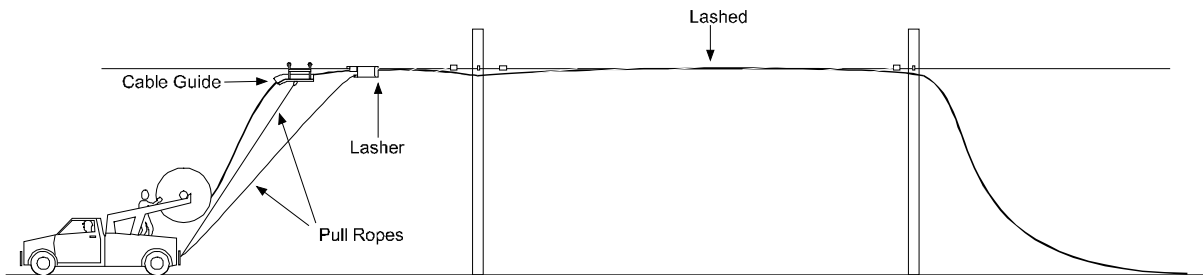

Figure 1. - The moving reel method of cable placement

1. The moving reel method is used when reel-carrying vehicles can drive the majority of the cable route. Using this method, the fiber optic cable is raised and lashed to the strand in one operation.

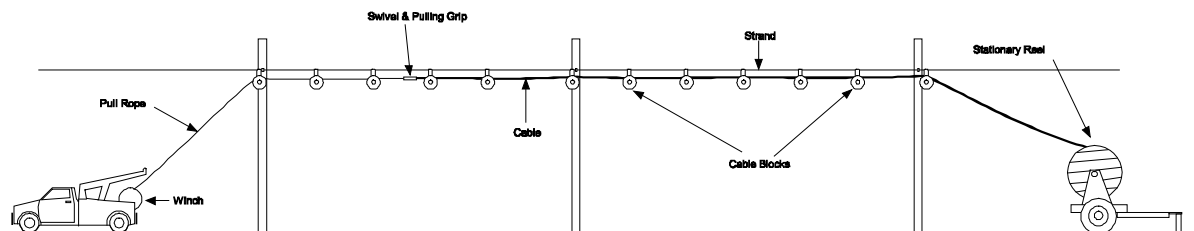

Figure 2. - The stationary reel method of cable placement

2. The stationary method is used when reel-carrying vehicles cannot drive the majority of the cable route. Using this method, the fiber optic cable is pulled into place beneath the strand using cable blocks. Lashing the cable to the strand then begins at the far end of the cable route with the lasher being pulled toward the stationary reel location at the near end.

3.0 PRECAUTIONS

- 3.01** The following are some suggested precautions that should be observed when working with fiber optic cables. Before starting any aerial fiber optic cable installation, all personnel must be thoroughly familiar with Occupational Safety and Hazard Act (OSHA) regulations. Also, company safety precautions for aerial fiber optic cable operations should be reviewed before work begins and practiced during the entire installation process.
- 3.02** Before cable installation begins, the cable reels should be carefully inspected for any imperfections such as nails, broken flanges, cable crossovers, or any that might cause damage to the cable as it is payed out. Precautions should be taken to protect stored reels from possible damage by vandals or other sources when left unattended. The thermal protective covering provided on each reel of fiber optic cable should always remain in place when storing reels.
- 3.03** Whenever cable from the reel is placed on the pavement or other surfaces, it should be protected with barricades or cones to prevent possible vehicular or pedestrian traffic damage. A "figure-eight" configuration should be used when the cable is removed from the reel and piled on the ground. This prevents kinking and twisting of the cable, which could cause damage. *Fiber optic cable should not be coiled in a continuous direction except for lengths of 100 ft (30 meters) or less. The minimum size for the "figure-eight" is about 15 ft (4.5 meters) in length with each loop 5 ft (1.5 meters) to 8 ft (2.4 meters) in diameter.*
- Note:** An alternative to the manual figure-eight procedure is the use of a figure-eight machine. This equipment will mechanically figure-eight cable much faster than is possible using the manual method. Using a figure-eight machine, a reel's remaining cable is mechanically removed from the reel to the machine's storage drum. This mechanical removal process provides much faster access to the cable's inside end using less manpower than does the manual figure-eight. Once the inside end has been freed, the procedure is reversed. With the figure-eight machine feeding the cable from its storage drum, the cable is pulled into place inside-end first. The machine's drum and rollers are specifically designed to prevent the cable from exceeding its minimum bend radius.
- 3.04** *Standard fiber optic cable has a maximum recommended pulling tension of 600 lbs. The maximum pulling tension is not to be exceeded.* Please consult PANDUIT's Best Practices for the proper installation and use of pulling grips. Cables may be ordered from the factory with pulling eyes already installed.
- 3.05** Fiber optic cables are more susceptible to performance degradation due to tight bending than are copper cables. The minimum bend radius of each cable is proportional to the cable's diameter. ***A general guideline is that a cable under tension should not be exposed to a bend radius less than 20 times the cable diameter and a cable with no tension should not be exposed to a bend radius less than 10 times the cable diameter.***
- 3.06** Never during the pull-in or lashing process should the cable experience sags, bends or twists, that produce a bend in the cable whose radius meets or exceeds that specified as the minimum bend radius for the cable being installed. Failure to observe proper cable handling procedures during cable placement can void the cable warranty and may result in permanent damage to the transmission characteristics of the cable. A reduction in the cable's transmission characteristics introduced during installation may not reveal itself until long after the installation process has been completed.

4.0 PRE-SURVEY

- 4.01** A pre-survey of the fiber cable route is very important in planning for an aerial optical fiber cable project. The purpose of a pre-survey is to determine if any work may be required along the proposed route before cable placement begins. Each section of the route must be properly prepared before cable installation begins.
- 4.02** One of the objectives of the pre-survey is to determine where each reel of fiber optic cable is to be placed. Slack locations and cable storage requirements must also be considered along with splice locations. The pre-survey will verify construction methods, special tools required, or possibly require a revision of preliminary splice locations.
- 4.03** The characteristics of the ground along the route need to be investigated. Trees or other obstructions, which could hinder placing operation, should be noted. Clearance issues over roadways, driveways, etc. need to be taken into account before cable placement begins. Consult the National Electric Safety Code (NESC) if uncertain of clearance requirements.
- 4.04** The method of cable placement and the tools necessary for placement are dependent upon vehicle accessibility to the cable route. In areas where a vehicle cannot go, the cable will need to be pulled in. In other areas with easy vehicle accessibility the cable can be lashed as it is taken off the vehicle's reel.
- 4.05** A good pre-survey will reveal clearance and separation issues on joint-use poles before they delay construction. It will also qualify the condition and size of the existing poles to be used, the condition and size of the existing pole's anchors and reveal the need for any new poles before placement operations begins.

5.0 MATERIALS AND EQUIPMENT

- 5.01** When an aerial lift truck is required for lashing operations, personnel in the aerial lift truck bucket will be responsible for directing all operations required in placing the lift into working position, using the lift, and restoring it to travel position. The operator of the truck will operate the truck only at the direction of the person in the lift bucket. There must be good communications between the person in the bucket and the driver of the truck.
- 5.02** A reel carrier or a cable trailer is required for transport and paying out of the cable as it is lashed to the strand.
- 5.03** A pulling eye or grip is used to provide a connection point between the cable and the pulling line. The pulling eye can be factory installed by the cable manufacturer. A pulling grip can be field installed provided *PANDUIT's* Best Practices are followed.
- 5.04** Cable blocks and snatch blocks will be required for placing cable when the moving reel method is not practical (See Figure 9 for an illustration of a snatch block).

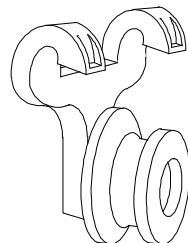

Figure 3 - Cable block

- 5.05** All slack cable storage locations require the installation of slack cable storage brackets. The slack cable storage bracket ensures a proper bending radius for the stored fiber optic cable and provides for horizontal storage and tiering for storage of multiple cables and loops.

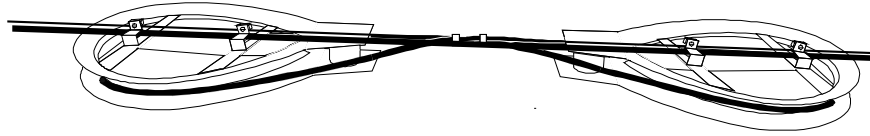

Figure 4 - Strand storage

- 5.06** The outside plant engineer responsible for the project determines strand requirements.
- 5.07** Lashing fiber optic cable to copper cable, either twisted pair or coaxial, increases the stress placed upon the fiber optic cable because of the difference in expansion coefficient, extra weight on the strand, and damage from work being conducted on adjacent cables. These factors can contribute to an accelerated failure of the fiber optic cable.
- 5.08** The lasher used to secure the fiber optic cable to the strand must be of the correct size to lash the cable without damaging the cable. If the lasher is undersized, it will put periodic dents in the cable as it passes along its length. When double lashing is required, wire must be loaded into both sides of the lasher. It is recommended that the operator of the lasher read and be familiar with the manufacturer's instructions for the lashing machine that they are using.

6.0 PLACING CABLE USING THE MOVING REEL METHOD

- 6.01** The moving reel method is used in locations where a cable reel trailer or aerial lift truck can be moved along the pole line and there are no obstructions between the reel and the suspension strand.
- 6.02** The moving reel method of cable placement has an advantage over the stationary reel method in that temporary cable blocks and pull-in lines are not necessary. Whenever possible, the moving reel method should be used.
- 6.03** When it is practical, the movement of the reel should be in the same direction as any nearby traffic.
- 6.04** Cable suspension clamps are to be tightened at least one span ahead of the cable lashing operation to prevent tension build-up in the strand as lashing progresses.
- 6.05** Start the cable lashing operation by removing enough cable from the reel to reach from strand level to a splicing vehicle below plus 16 feet or so of extra slack.

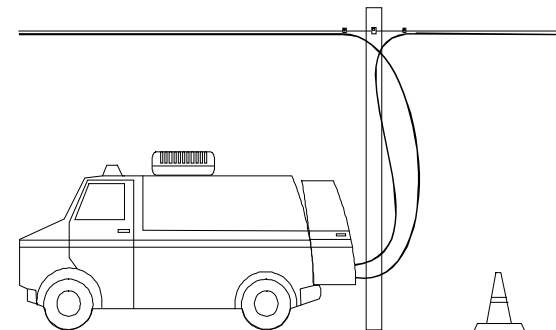

Figure 5 - Splice van location

- 6.06** Lift the cable guide and lasher to the strand. Using a lift or a hand line, raise the cable up to the strand and pass it through the cable guide, positioning the cable in the lasher. The lashing wire should be placed around the tension rollers and then terminated in the lashing wire clamp.

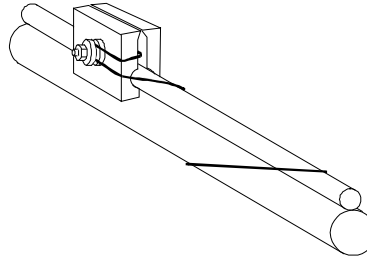

Figure 6 - Lashing wire clamp

- 6.07** Attach separate pulling lines from the vehicle to the lasher and the cable guide

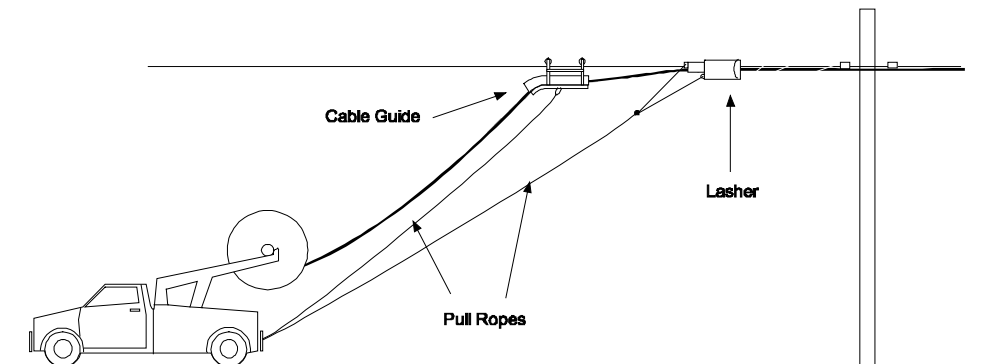

Figure 7 - Setup for moving reel method

- 6.08** As the reel movement begins, secure the cable at the pole to prevent any movement along the strand until the lasher has moved 50 feet down the strand.
- 6.09** The cable reel must allow smooth cable pay-out to allow the cable to smoothly enter the cable guide at stand level. Hand pull cable from the reel to ensure a tension-free feed into the cable guide preceding the lasher.
- 6.10** The reel-carrying vehicle should maintain an approximate 50-foot lead distance ahead of the lasher, and drive as close to the pole line as possible.
- 6.11** If it becomes necessary to stop the lasher mid-span, a proper tension and bend radius of the cable must be maintained at the lasher.
- 6.12** Upon reaching a pole:
1. Clamp the lashing wire to the strand.
 2. Transfer the guide, lasher, etc., to the other side of the pole.
- 6.13** Continue the cable installation, span-by-span from the starting point towards the end of the cable until the entire cable run is completely lashed and properly sagged.

7.0 PLACING CABLE USING THE STATIONARY REEL METHOD

7.01 Unlike the moving reel method in which the cable placement and lashing operations take place at the same time, the stationary reel method requires two separate operations.

- First: the cable is pulled into place beneath the strand supported by cable blocks (See Figure 8).
- Second: the cable is then lashed to the strand beginning at the cable end and ending at the stationary reel location (See Figure 10).

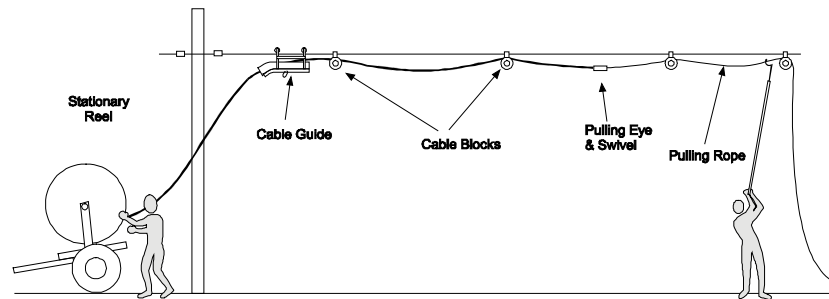

Figure 8 - Setup for stationary reel method

7.02 Cable reel trailers should be disconnected from their towing vehicles. The reel should be leveled and the trailer wheel securely chocked.

7.03 A cable guide should be installed to guide the cable from the reel to its position beneath the strand.

7.04 If it has not been installed by the factory, attach a pulling eye or pulling grip to the cable. This in turn must be attached to a pulling swivel and the pulling swivel attached to a pulling rope.

7.05 Cable blocks are suspended beneath the strand to receive the pulling rope and to act as temporary supports for the cable as it is pulled in. Use a cable block of appropriate size for the cable being pulled.

7.06 All cable blocks are to be placed on the strand facing the same direction with their locking levers (if present) set to release as the lasher strikes them.

7.07 Cable blocks are to be set at a maximum distance of 50 feet apart on the strand. When local company's practices call for closer intervals follow that practice. Make sure a sufficient number of blocks are available before installation begins.

7.08 Attach the pulling rope to the pulling swivel that has been connected to the pulling eye or pulling grip on the cable.

7.09 Begin unrolling the cable, lifting it up to strand level and through the cable guide as tension is applied to the pulling rope. Control the rotation of the reel to prevent free running of the cable.

7.10 The pull begins with the rope running through the cable guide and over the first cable block. As the cable pays out, the rope is then lifted and placed into the second cable block and the pull continues.

7.11 For winch-assisted pulls, the pulling rope is first placed in position through all the cable blocks from the stationary reel's location to the winch's location. The entire length of cable is then pulled in using the winch's pulling force (See Figure 2).

- 7.12** Where the cable route changes direction snatch blocks must be used to make each corner.

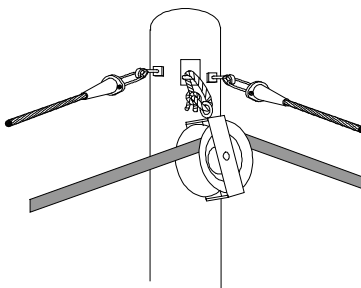

Figure 9 - Snatch block

- 7.13** With the cable pulled into place beneath the strand and supported by cable blocks, the next step in the procedure is to lash the cable to the strand.
- 7.14** First, install the necessary spacers and straps at the pole farthest from the reel end. Then place the lasher on the strand and prepare it for lashing as per the instructions for the type of lasher being used. Stranding must begin at the far end and proceed towards the reel end with any cable slack being worked back towards the reel.
- 7.15** The lashing operation is begun by the lasher being pulled by rope along the path of the strand. The lasher must be pulled with a downward pressure to keep the lasher mechanism spinning. Always maintain tension on the lasher to keep the lashing wire from wrapping the fiber optic cable around the strand.

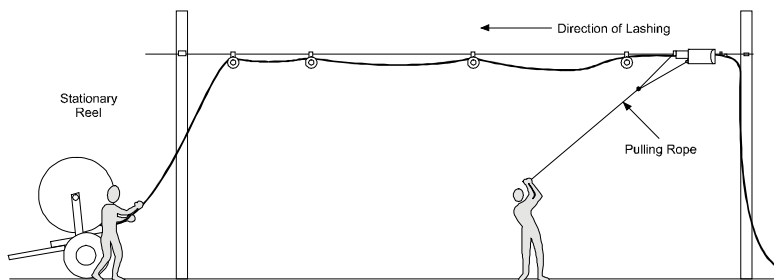

Figure 10 - Pull-back lashing of cable

- 7.16** The lasher is pulled the length of the span to the next pole. The cable blocks are pushed ahead of the lasher as it progresses down the cable route. Upon reaching the next pole, the cable blocks are removed from the strand.
- 7.17** Before releasing the lasher brake, the lashing wire must be temporarily clamped to the stand with a clamp. After the wire is secured, enough wire must be pulled out of the lasher for termination before cutting.
- 7.18** Transfer the lashing equipment to the other side of the pole and continue the lashing operations. Be sure to check all work at each pole before continuing on to lashing the next span.
- 7.19** Each span must be securely lashed into place starting at the pull end and proceeding back to the reel's location. Cable slack must be carefully worked ahead of the lasher, span-by-span, back to the cable reel. Each span's lashing wire must be secured to a lashing wire clamp before moving the lasher to the next span. This process continues until the entire cable run is lashed and properly sagged.